

The skin effect shows up with TDR measurements as a decline of the slope of the TDR step function. This is due to the fact that different frequencies that form the ideal step function, are traveling with different speed along the delay line.

## FREQUENCY DOMAIN

With network analyzers, this effect is visible in  $S_{21}$  as a decrease in magnitude. Conventional SPICE models, however, cannot cover this effect. It only allows the modeling of ideal delay lines without a decrease in magnitude. /Katzier/ proposes a special SPICE subcircuit which can be used to model this skin effect. It is given together with an additional ideal SPICE delay line in the SPICE deck of figure 1 below.

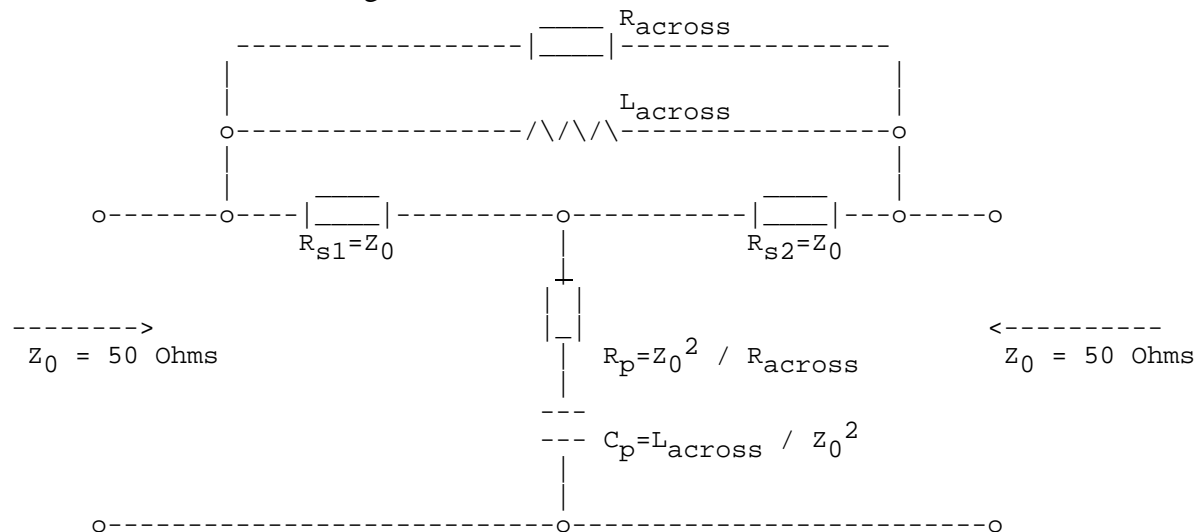

Fig.1: SPICE equivalent schematic for modeling the skin effect after /Katzier/.

$L_{\text{across}}$  and  $R_{\text{across}}$  are modeling the damping of  $|S_{21}|$ . Here,  $L_{\text{across}}$  is the most important fitting parameter and  $R_{\text{across}}$  is used for fine-tuning. Note that the main effect is the variation in the magnitude, while the phase is only little changed.

The SPICE deck looks like in figure 2:

```
.SUBCKT mdlskin 1=P1 20=P2

*----begin skin effekt model----
Rs1 1 3 Z0
Rs2 3 2 Z0
Lacross 1 2 1n
Racross 1 2 10
Rp 3 33 Z0^2//Racross
Cp 33 0 Lacross//Z0^2
*-----end skin effect model-----

T1 2 0 20 0 Z0=50 TD=200p

.ENDS
```

Fig.2: SPICE input deck for the circuit of fig.1

### 3.8.2.: skin effect -2-

The performance of this model including the ideal delay line is given with the next 3 plots. Note that the skin effect model affects mainly the decrease in magnitude of S21. On the other hand, it affects the phase shift of the ideal delay line only a bit.

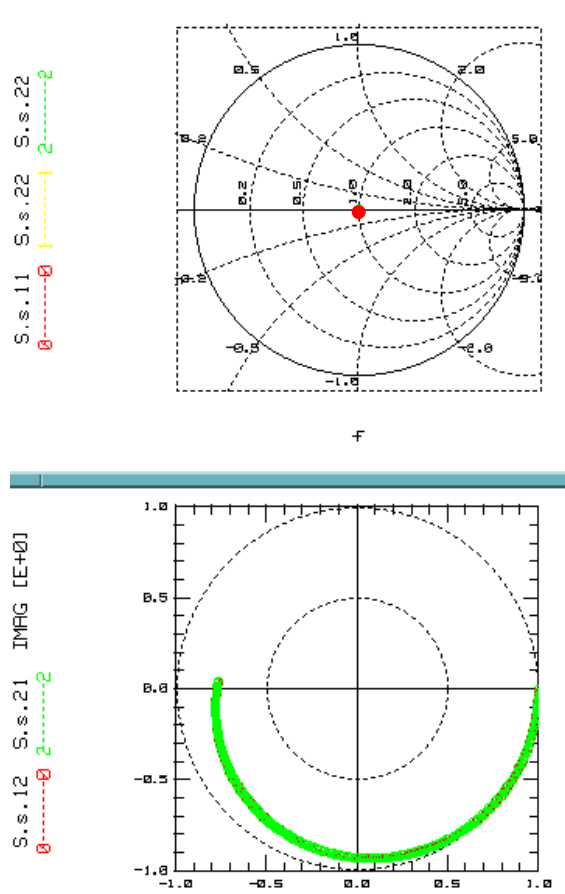
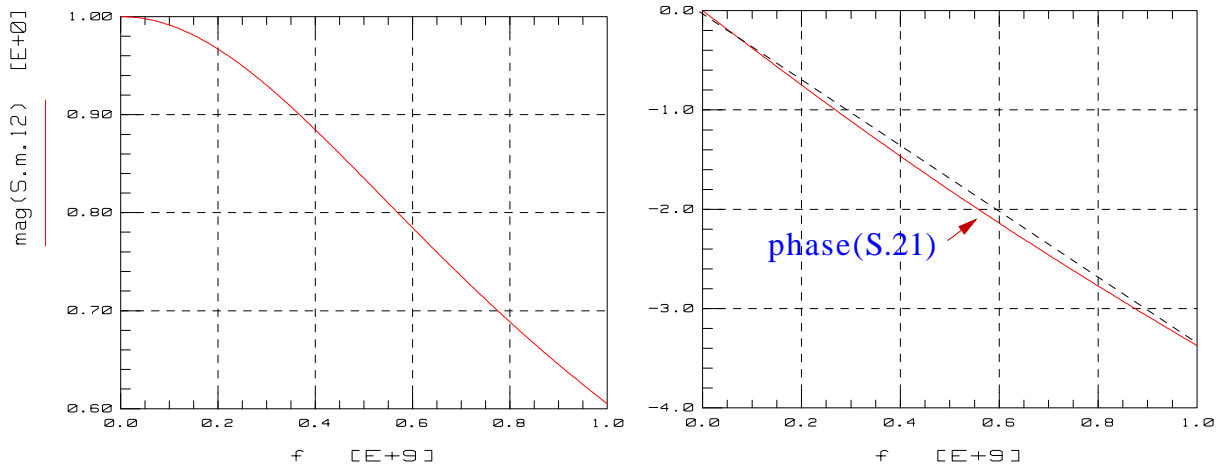

Fig.3a: Skin effect with S-parameters.

Note: Sxx is not affected by the schematic of fig.1.



Note: the dotted straight line in the phase plot is for reference only.

Fig.3b: Skin effect with S-parameters: magnitude and phase

TIME DOMAIN

In the time domain, the skin effect is visible as a quasi-'lowpass' slope of the back-reflected step response. The following figure 4 shows a modeling of sequence of delay lines with and without the skin effect. Again,  $L_{ACROSS}$  and  $R_{ACROSS}$  were used to tune the slope.

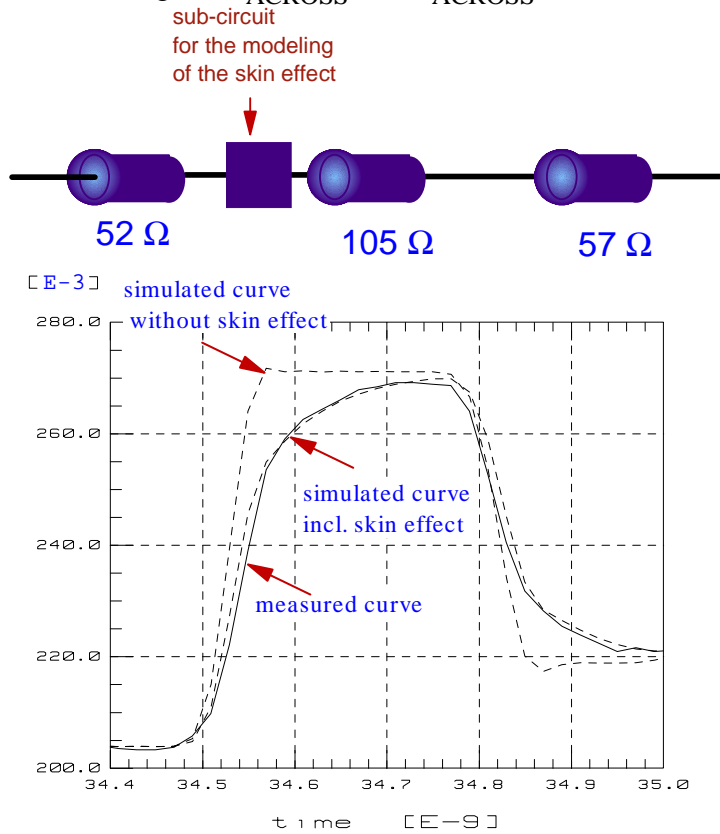

Fig.4: Skin effect with TDR measurements

Applied to a Gaussian impulse, the skin effect becomes visible with a unsymmetrical impulse response with an undershoot. This proofs nicely the plot of fig.4, since a step function is the integral of a pulse.

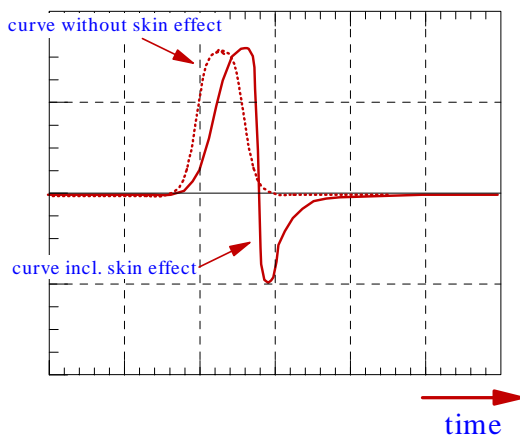

Fig.5: A Gaussian pulse affected by the skin effect

Some few words about the

## DISPERSION EFFECT

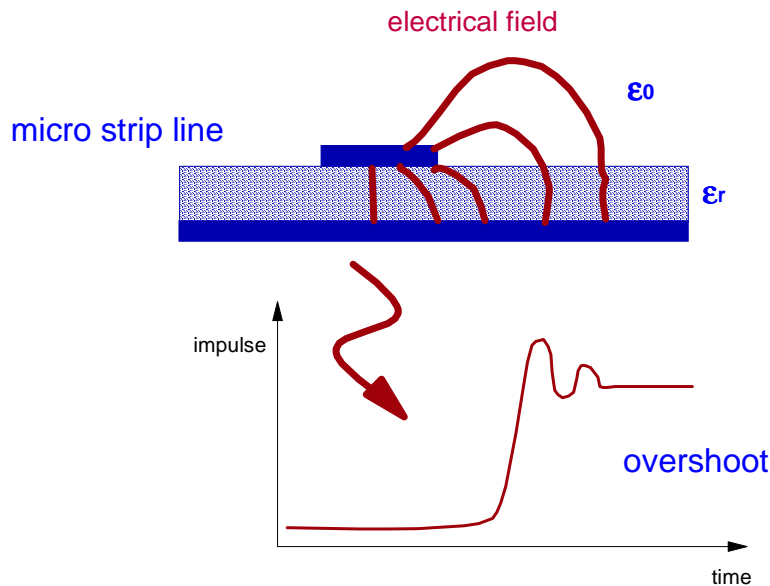

Fig.6: the dispersion effect

Provided we have a micro strip line on a printed circuit (PC) board, part of the electromagnetic field goes through the printed circuit board material, whereas a (smaller) part goes through both, this PC material and the air. This results in a combined and non-linear total dielectric constant  $\epsilon_{total}$  and in a distorted impulse shape like that one sketched in fig.6. To model this effect, special simulators with special models like HP's MDS simulator have to be used. Spice does not include a model for this effect.

Publications:

H.Katzier: Analyse und Modellierung der Gesamtdämpfungverluste von verlustbehafteten Streifenleitungen, 4.GMM/ITG Diskussionssitzung, October 1996, Berlin